

# T8002

## Air Boss® T-Series



**TRION®**  
Air Purification Systems

### Top View

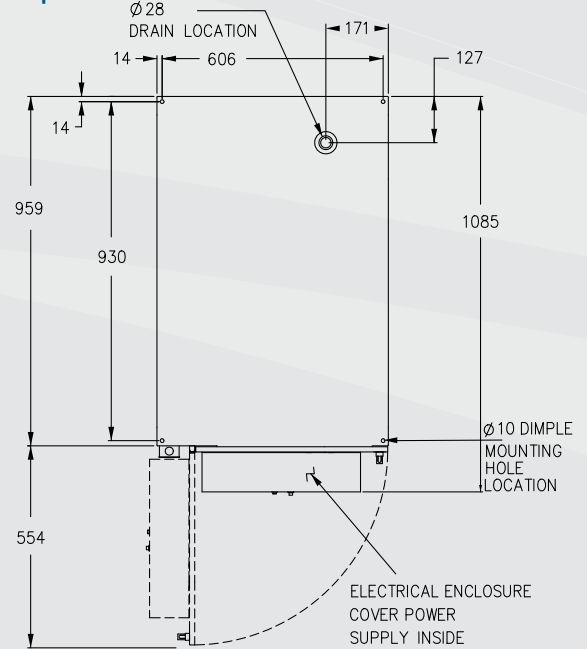

### Discharge End

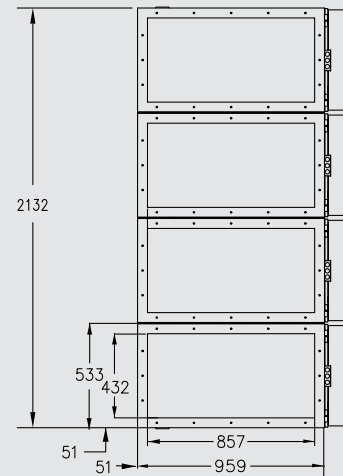

### Front View & Intake End

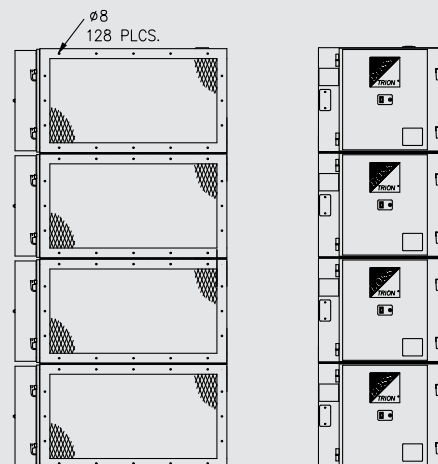

T8002	
<b>Dimensions</b>	635L x 1085W x 2153H mm
<b>Installation</b>	Suspended, Wall or Frame Mounted
<b>Unit Weight</b>	320 kg
<b>Input Voltage</b>	230Vac/1phase/50 Hz
<b>Cell Power</b>	200 watts
<b>Output Voltage</b>	12 kV/6 kV
<b>No of cells</b>	8
<b>Cell Weight</b>	15 kg
<b>Air Volume</b>	13260 - 17680 m <sup>3</sup> /hr
<b>Controls</b>	On/Off Switch with Indicator
<b>Pre-filter</b>	Aluminum Standard Mesh (8 Req.) (Optional Impinger)
<b>Primary Filter</b>	Electronic Ioniser/Collector Cell
<b>After Filter</b>	Optional Disposable Charcoal After Filter
<b>Power Supply</b>	High Frequency Solid State Design
<b>Efficiency</b>	To 95% Based on D.O.P. Test Method To 99% For Double Pass (Calculated)
<b>General</b>	Multiple Units Can Be Joined Together for Increased Volume or Efficiency

Trion® a division of Ruskin Air Management Ltd.

The Cavendish Centre | Winnall Close | Winchester | Hampshire, UK. | SO23 0LB  
P: +44 1962 840465 | F: +44 1962 828619 | www.trioninc.com | TrionEMEAservice@airsysco.com